

ABM

ergonomic style

multiClip™ Tour / *multiClip™* Sport

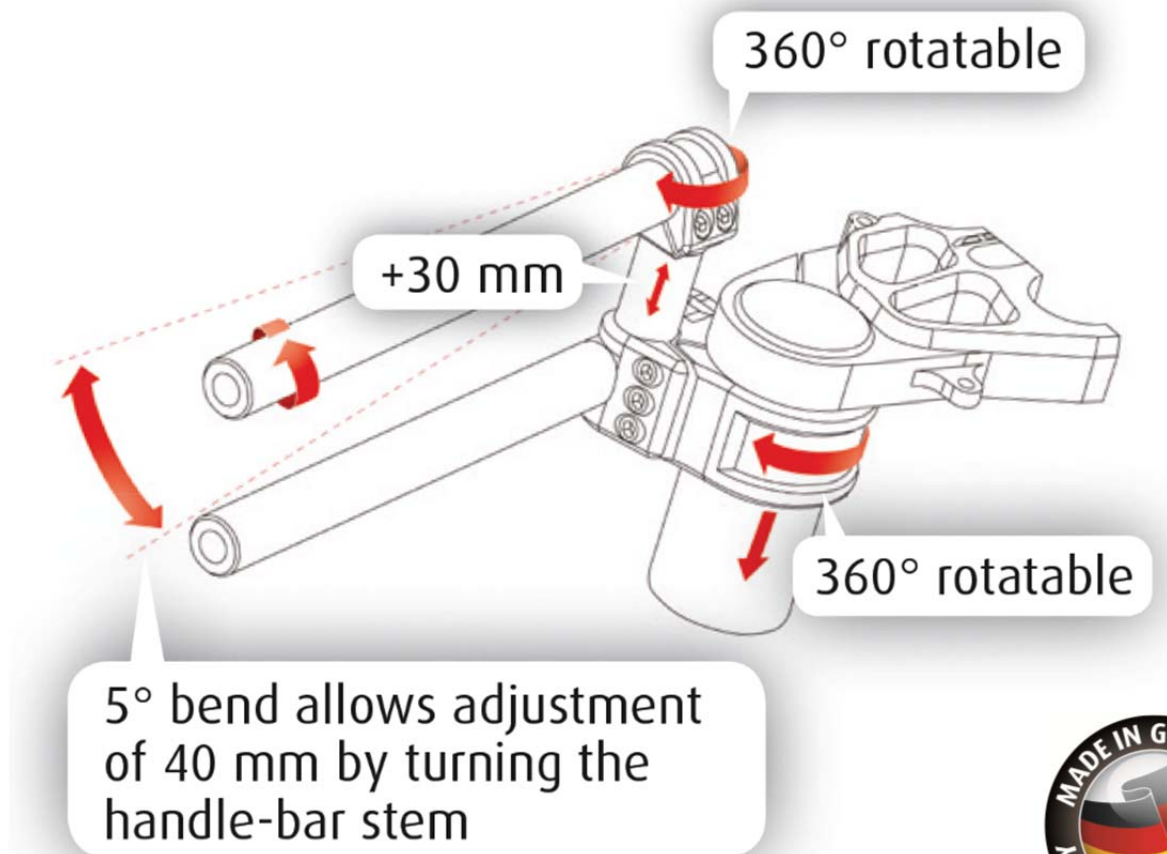

**General Fitting Instruction
and
Safety Advices**



Attention



Important Safety Advices:

- Working on steering- or braking-system is safety-relevant. Improperly fitting can reduce your motorcycle's driveability and may be a risk of serious injuries or death. You should do this work only if you're qualified and in possession of an official workshop manual as well as all relevant service bulletins. Otherwise this mounting is recommended to be done, or at least checked, by a qualified workshop.
- Brake fluid is harmful to many surfaces and materials. Protect all other parts from brake fluid. Mind all safety advices supplied by the brake fluid manufacturer.
- Use only fresh brake fluid from a sealed container. Always use new seal-rings according to the brake-hose manufacturer's instruction. Never combine copper seal-rings with fittings made from aluminium.
- Brake systems with ABS should always be bled in a qualified workshop, which is authorized by the vehicle manufacturer.
- Adhere to the workshop manual for all works and tightening torques on original parts.
- Assure all clamping's contact faces are clean, dry and free from damage during the assembly. Always protect these contact faces from any friction decreasing substances (e. g. oil, silicone, care products, etc.). This is vital to a safe function of the *multiClip*.
- Necessarily tighten all clamping bolts with recommended torque as shown on page 3. These tightening torques are only valid for dry bolts and threads. Always check for loosened bolts during normal inspection.
- It's on your own responsibility to check this product regularly for service or replacement.
- Please mind that *multiClip* is a safety-relevant part on you motorcycle. Always check clip-ons after any kind of accident or tumbled bike. Replace whole *multiClip* at least sign of damage.
- Never use this clip-ons to lash the motorcycle.
- Always check your local laws for using aftermarket parts on your bike.
- This accessory was designed for a series-production vehicle. ABM[®] Fahrzeugtechnik GmbH disclaims any liability or warranty for all damages that occur by improper fitting, lacking maintenance or incompatibility to accessories which are not approved by ABM[®]

1 Work Preparation

- Read safety advices and fitting instruction completely and carefully.
- This fitting inhabits the risk of a tumbling down vehicle! Park the motorcycle on a firm and flat surface and protect it from tumbling down or rolling away.
- Keep children and pets away from the working range.

General Fitting Instruction *multiClip*TM Tour / *multiClip*TM Sport

- Protect temporarily removed parts from damage.
- Assure that the front wheel is free from any load when removing or mounting top yoke, otherwise the bottom yoke might be damaged.
- Accurately record demounted parts' and related bolts' locations. If not otherwise mentioned, these parts are reassembled in same sequence and locations as before

2 Content and Recommended Accessories

Special tooling required?	Torque wrench	Assembly time:	approx. 4-6 hours
Advice: Our <i>multiClip</i> clip-on handlebar is a fully adjustable handlebar system. Possible adjustments are strongly depending on the motorcycle's building type and available space.			

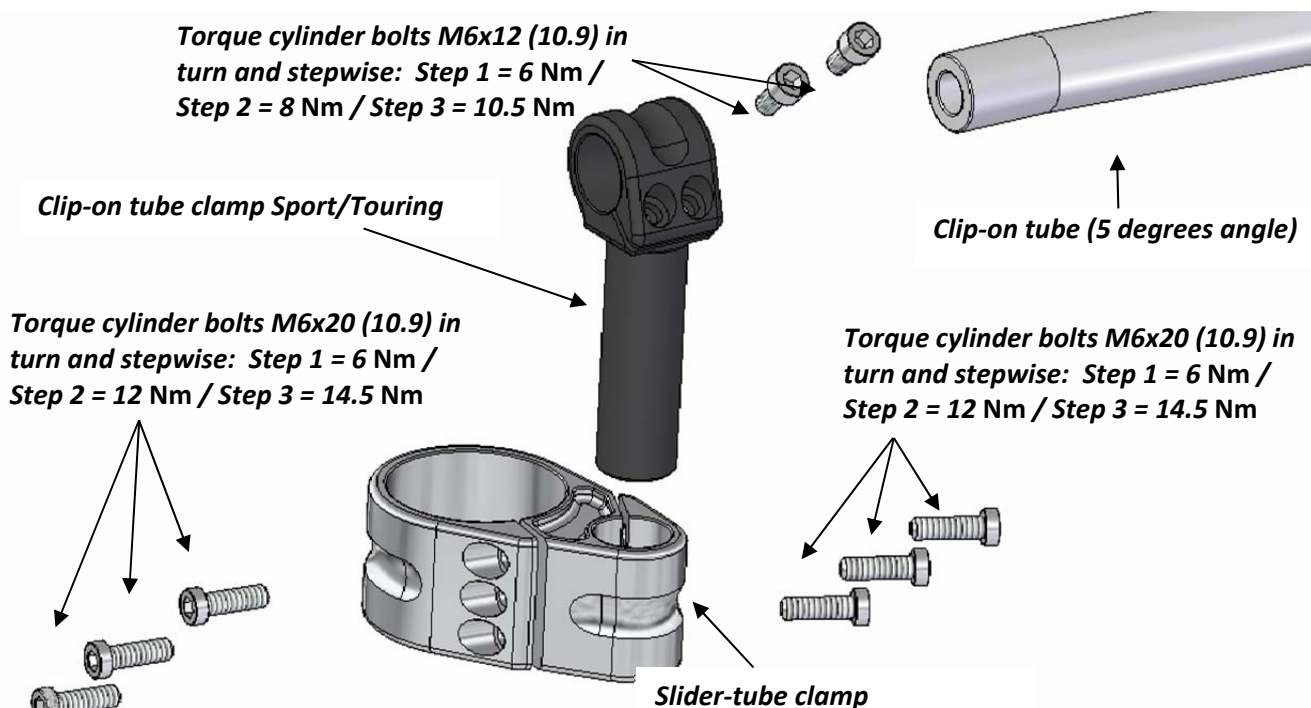

We can offer several options to support your conversion:

- Stainless steel flex hoses for clutch and brake with your desired length.
- We are able to elongate all Bowden cables (e. g. throttle cables). Therefore you need to send us those Bowden cables with a specified amount of elongation.
- A wide superbike accessories program, e. g. spacer for fairing and mirrors, relocation brackets for reservoirs, etc.
- Yamaha YZF-R1 models from 2004 'til 2008 require an additional steering damper bracket.

3 Fitting

- Demount top yoke and remove all controls and switch-units from clip-ons or handlebar, according to the workshop manual.
- Preassemble delivered parts as shown in the drawing.
- Slip both *multiClip* assys over the left and right slider-tube and fix them slightly with their clamping bolts. Watch for those ABM-Logos, you should see them when sitting on the motorcycle.
- If clip-on is mounted with a reducing bush (optional accessory), assure the reducing bush is flush mounted between clamp and slider-tube and the slots of bush and clamp are aligned to each other when fixing it.
- Remount top yoke while *multiClip* is only slightly fastened.
- Provisorily mount controls, clutch lever bracket and brake cylinder assy.
- Adjust clip-ons to your desired position.
- To fix the controls finally it's necessary to drill holes for the anti-twist pins. Align controls and mark the corresponding spots on tubes (apply a small amount of grease on the pin and press controls against tube). Centre-punch these marks and drill the appropriate bores (diameter and depth according to the pin).
- Reassemble all remaining parts, according to the workshop manual.

4 Final Checking

- Assure that alignment of all controls and switch-units grants full functionality, even at maximum steering angle. Reservoir and master brake cylinder need to be aligned and angled in their normal working range.
- Make sure no cables, hoses or harnesses are sharp bended and also stay tension-free over the whole steering angle and fork spring travel. Prevent chafe marks as well.
- Minimum bending radius of any brake-hose should not go below 40 mm.
- Check sufficient clearance for handlebar and all bar-mounted parts over the whole steering angle. Handlebar has to move easily from stop to stop. Adjust throttle cables if necessary. With idling engine idle speed should not change when moving bar over the whole steering angle.
- Finally check function and fixation of all parts as well as brake system's leak tightness. Assure the brake-fluid reservoir is filled sufficient. Test front wheel for easily revolving and brake response. Check clutch, throttle, electrical system and anti-theft device as well.
- A test-ride is necessary now! Afterwards, check all bolted connections for tightness, brake system for leak tightness and all moving part for sufficient clearance. Test front wheel for easily revolving again and brake system for overheating. Check reservoir's brake-fluid level for significant changes.
- A 100 kilometres later, all bolted connections need to be tightened again, with recommended torque.

Eine deutsche Version ist ebenfalls verfügbar. Siehe: www.ab-m.de